

UNDERCOUNTER REFRIGERATORS

Model	Product ID	Size
KUC61R	919623	61 1/5" Unit

STANDARD FEATURES

- Solid state thermostat w/ digital display
- Stainless steel front & sides
- Self-closing doors remain open past 90°
- Environmentally friendly R600A
- EZ slide out condenser
- Whisper quiet
- Solid construction
- Full length integrated door handle
- Casters w/ two front brakes
- Cool air intake
- 2" clearance back & sides
- Heavy duty baked Epoxy coated wire shelves



KUC61R

WARRANTY

Kintera refrigeration equipment is warranted to be free from defects in material and workmanship under normal use and service for a period of 2 years for parts and labor. The compressor carries an additional 3 year warranty for the part only.

Items	Description	Items	Description
Front, top & sides	Stainless steel	Temperature control	Solid state thermostat w/ digital display
Doors	Stainless steel/ABS liner	Approvals	UL-EPH
External back	Aluminum	Refrigerating system	Capillary tube
Cabinet interior	ABS	Refrigerant	R600A
Interior floor	300 Series stainless steel	Temperature range	34°F to 38°F
Insulation	Polyurethane (CFC free)	Evaporator	Powder coated aluminum/copper
Shelves	Heavy duty, Epoxy coating	Condensing unit	Rear mounted

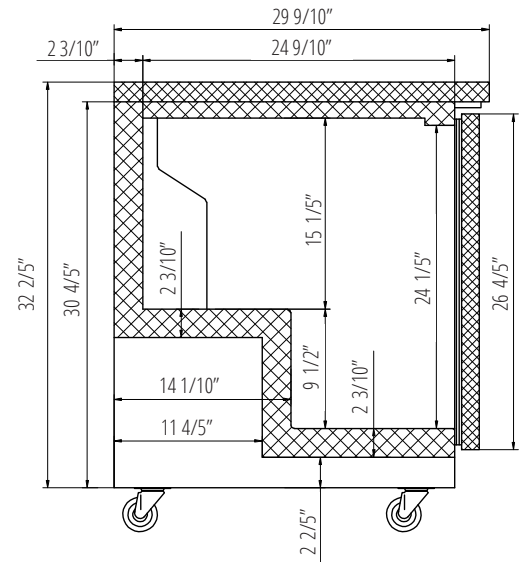
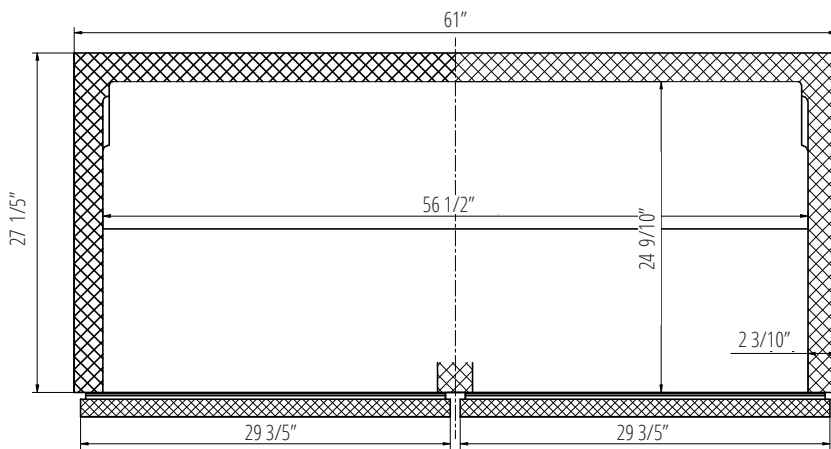
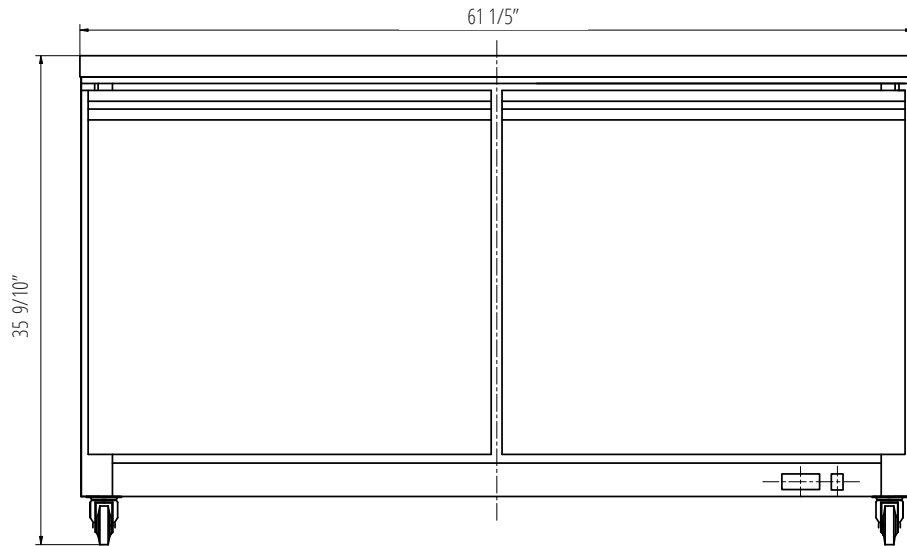

Model	Product ID	Doors	Capacity (cu ft)	Shelves	Cabinet Dimensions (in)			HP	Voltage	Amps	NEMA Plug	Cord Length (ft)	Crated Weight
					W	D	H						
KUC61R	919623	2	15.50	2	$61 \frac{1}{5}$	$29 \frac{9}{10}$	$35 \frac{9}{10}$	$\frac{3}{8}$	115/60/1	3	5-15P	10	330